



REALTEK

RTS5105 V1.1

USB 2.0 Card Reader Controller

Datasheet

Doc Rev. 1.1

22 AUG 2005



REALTEK

Realtek Semiconductor Corp.

No. 2, Industry E. Rd. IX, Science-Based Industrial Park, Hsinchu 300, Taiwan

Tel: +886-3-5780211 Fax: +886-3-5776047

www.realtek.com.tw

TRADEMARKS

Realtek is a trademark of Realtek Semiconductor Corporation. All other names mentioned in this document are trademarks/registered trademarks of their respective owners.

Realtek provides this document “as is”, without warranty of any kind, neither expressed nor implied, including, but not limited to, the particular purpose. Realtek may make improvements and/or changes in this manual or in the product(s) and/or the program(s) described in this manual at any time. This document could include technical inaccuracies or typographical errors.

Revision History

Revision	Description	Page	Date
1.1	Support MMC 4.x	1	2005/08/22
1.00	Add Electrical Characteristic values	6	2004/07/15
0.92	Modify pin50 pin description	3,5	2004/03/24
0.91	Modify GPIOB_7 pin description	3	2004/03/24
0.9	Preliminary release		2004/02/11

Table Of Contents

1. GENERAL DESCRIPTION	1
2. FEATURES	1
3. BLOCK DIAGRAM.....	2
4. PIN DESCRIPTIONS	3
4.1 USB Transceiver.....	3
4.2 System Interface	3
4.3 EEPROM Interface	3
4.4 NAND Flash Memory Interface	3
4.5 SecureDigital / MultiMediaCard Interface	4
4.6 Memory Stick PRO / Memory Stick Interface.....	4
4.7 Power and Ground.....	4
4.8 I/O Type Description	4
5. PIN ASSIGNMENT	5
6. ELECTRICAL CHARACTERISTICS	6
6.1 Absolute Maximum Ratings.....	6
6.2 DC Characteristics.....	6
7. PACKAGE DIMENSIONS	7

1. General Description

The RTS5105 is a high performance USB 2.0 card reader controller that integrates USB 2.0 PHY and SIE, 8051 MCU, ROM, RAM, and memory card controller on a single chip. It supports access to Memory Stick™, Memory Stick PRO™, SecureDigital™, MultiMediaCard™, and NAND flash memory. With the built-in high-speed USB 2.0 device controller, the RTS5105 provides a 480Mbps transfer rate in addition to full-speed 12Mbps of the USB 1.1 specification.

Designed with an enhanced power control circuit, the RTS5105 fully complies with USB power specifications for bus-powered devices, making it capable of bus-powered operation. Conforming to USB Mass Storage Class Specification, RTS5105 provides plug and play convenience without any driver installation effort.

The external serial EEPROM interface provides flexibility in storing customer USB Vendor ID, Product ID, and also customer content such as vendor information, product information, revision level, and serial number. The RTS5105 provides an In-System Programming (ISP) capability for manufacturing flexibility; the customer information is programmed into the external EEPROM at production. This four-bit EEPROM interface can be programmed to function as general-purpose I/Os.

With a few external components required, the LQFP 64-pin packaged RTS5105 provides the best cost/performance for high-performance USB2.0 flash memory card reader/writer applications.

2. Features

- Compliant with Universal Serial Bus Specification Revision 2.0
- Compliant with USB Mass Storage Class Bulk only Transport Specification Rev. 1.0
- Supports High-speed (480Mbps) and Full-speed (12Mbps) Data Transfer
- Supports USB bus power operation
- Supports Control, Bulk and Interrupt USB data pipes
- Supports the following memory card interfaces:
 - Secure Digital™ (SD), MultiMediaCard™ (MMC)
 - Memory Stick™ (MS), Memory Stick PRO™ (MS-PRO)
 - NAND Flash Memory
- Supports hardware ECC (Error Correction Code) function
- Supports hardware CRC (Cyclic Redundancy Check) function
- Programmable clock rate for flash memory card interfaces
- Supports MS/MS-PRO 4-bit parallel transfer mode
- Support MMC 4.x for 1/4-bit data mode with 26Mhz
- Integrated Fast 8051 microprocessor

- External serial EEPROM interface
- 12MHz crystal oscillator with integrated PLL
- Single 3.3V operating voltage
- 64-pin LQFP package

3. Block Diagram

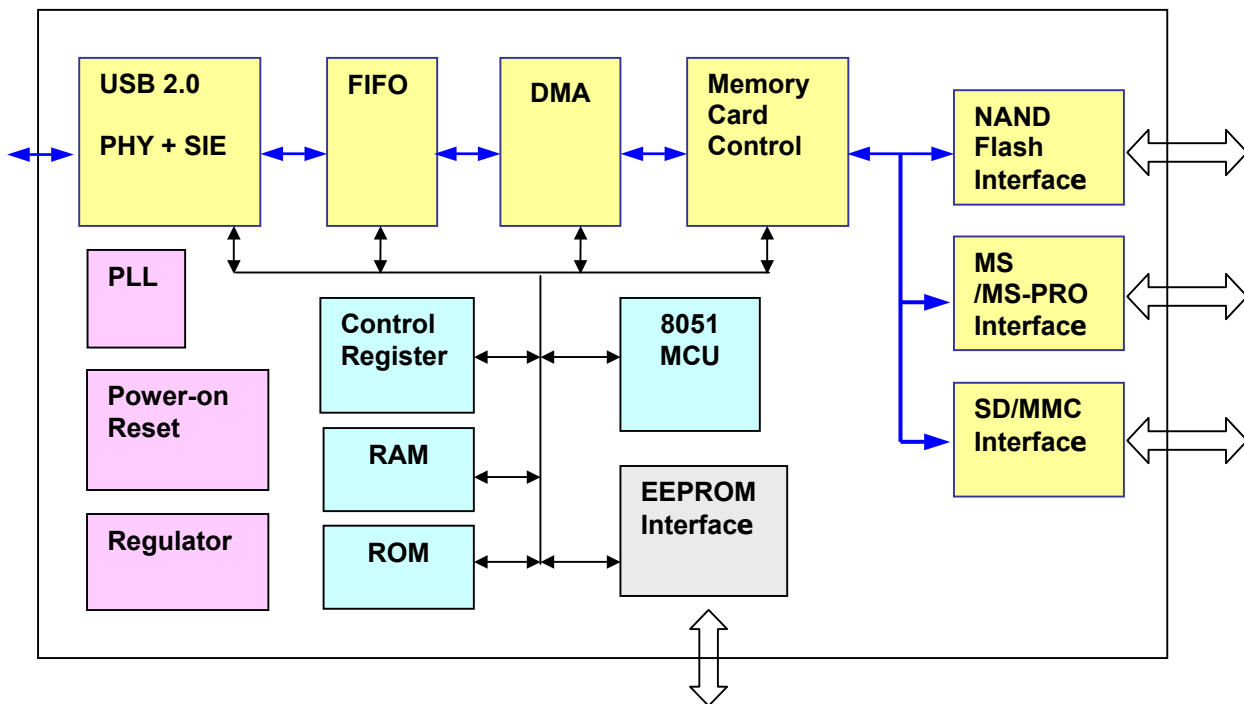

Figure 1. Block Diagram

4. Pin Descriptions

4.1 USB Transceiver

Name	Type	I/O Type	Pin No.	Description
HSDP	I/O	IO-U	7	High speed USB D+ signal
HSDM	I/O	IO-U	5	High speed USB D- signal
FSDP	I/O	IO-U	8	Full speed USB D+ signal
FSDM	I/O	IO-U	6	Full speed USB D- signal
RPU	N/A	IO-U	9	Connect external resistor (1.5kΩ ± 1%) to Analog Power AVDD
RREF	N/A	IO-U	12	Connect external resistor (6.19K ± 1%) to Analog Ground AGND

4.2 System Interface

Name	Type	I/O Type	Pin No.	Description
XI	I	CLK	3	Crystal oscillator input (12 MHz). Also can be used as external clock input
XO	O	CLK	2	Crystal oscillator output (12 MHz)
RST#	I	IOSH	16	System reset
GPIOA_0	O	IOH	53	General purpose I/O
GPIOA_1	O	IOH	51	This pin is used as Secure Digital™ card power switch.
GPIOA_3	O	IOH	44	This pin is used as Memory Stick™ card power switch.
GPIOB_6	O	IOH	49	LED indicator of accessing any memory card.
MODE [0:1]	I	IO	59, 58	These pins are test pins. Connect these pins to digital ground for normal operation.

4.3 EEPROM Interface

Name	Type	I/O Type	Pin No.	Description
EECS	O	O	63	Chip select
EESK	O	O	62	Clock signal
EEDI	I	IOL	60	Serial data in
EEDO	O	IO	61	Serial data out

4.4 NAND Flash Memory Interface

Name	Type	I/O Type	Pin No.	Description
SM_D [0:7]	I/O	IOL	54,52,46,45,43,41,27,25	Multiplexed address, command and data bus for SM card
SM_ALE	O	O	18	Address latch enable
SM_CLE	O	O	19	Command latch enable
SM_RE#	O	O	20	Read enable
SM_WE#	O	O	17	Write enable
SM_RDY	I	IOH	21	Ready/Busy
GPIOB_0	O	IOH	39	NAND flash memory chip enable

4.5 SecureDigital / MultiMediaCard Interface

Name	Type	I/O Type	Pin No.	Description
SD_DAT [0:3]	I/O	IOH	33,34,29,30	Serial protocol data signal
SD_CMD	I/O	IOH	31	Serial protocol command and response signal
SD_CLK	O	O8	32	Serial protocol clock signal
SD_WP	I	IOH	28	Write Protect switch signal
GPIOA_7	I	IOH	24	Card detect

4.6 Memory Stick PRO / Memory Stick Interface

Name	Type	I/O Type	Pin No.	Description
MS_INS#	I	IOH	37,	Card detect
MS_BS	O	O	35	Bus state
MS_SDIO	I/O	IOL	36	Memory Stick™ data signal/ Memory Stick PRO™ data signal 0
MS_CLK	O	O	38	Clock signal
MS_D1 (GPIO A4)	I/O	IOL	42	Memory Stick PRO™ data signal 1
MS_D2 (GPIO A5)	I/O	IOL	40	Memory Stick PRO™ data signal 2
MS_D3 (GPIO A6)	I/O	IOL	26	Memory Stick PRO™ data signal 3

4.7 Power and Ground

Name	Type	I/O Type	Pin No.	Description
AVDD	Power	Power	4,13	Analog power
AGND	Power	Ground	1,10,11,64	Analog ground
VREG	Power	Power	15	Analog regulated supply voltage (2.5V ±10%) from internal 3.3V to 2.5V regulator; supplies internal digital circuits. An external capacitance should be connected
DVDD	Power	Power	22,47,57	Digital power
DGND	Power	Ground	23,48,56	Digital ground

4.8 I/O Type Description

I/O Type	Description
O	Output
IO	Input / Output
IOL	Input / Output with internal pull-down 200K
IOH	Input / Output with internal pull-up 200K
IOSH	Input / Output with Schmitt trigger
IO-U	USB related IO
CLK	Clock related IO

5. Pin Assignment

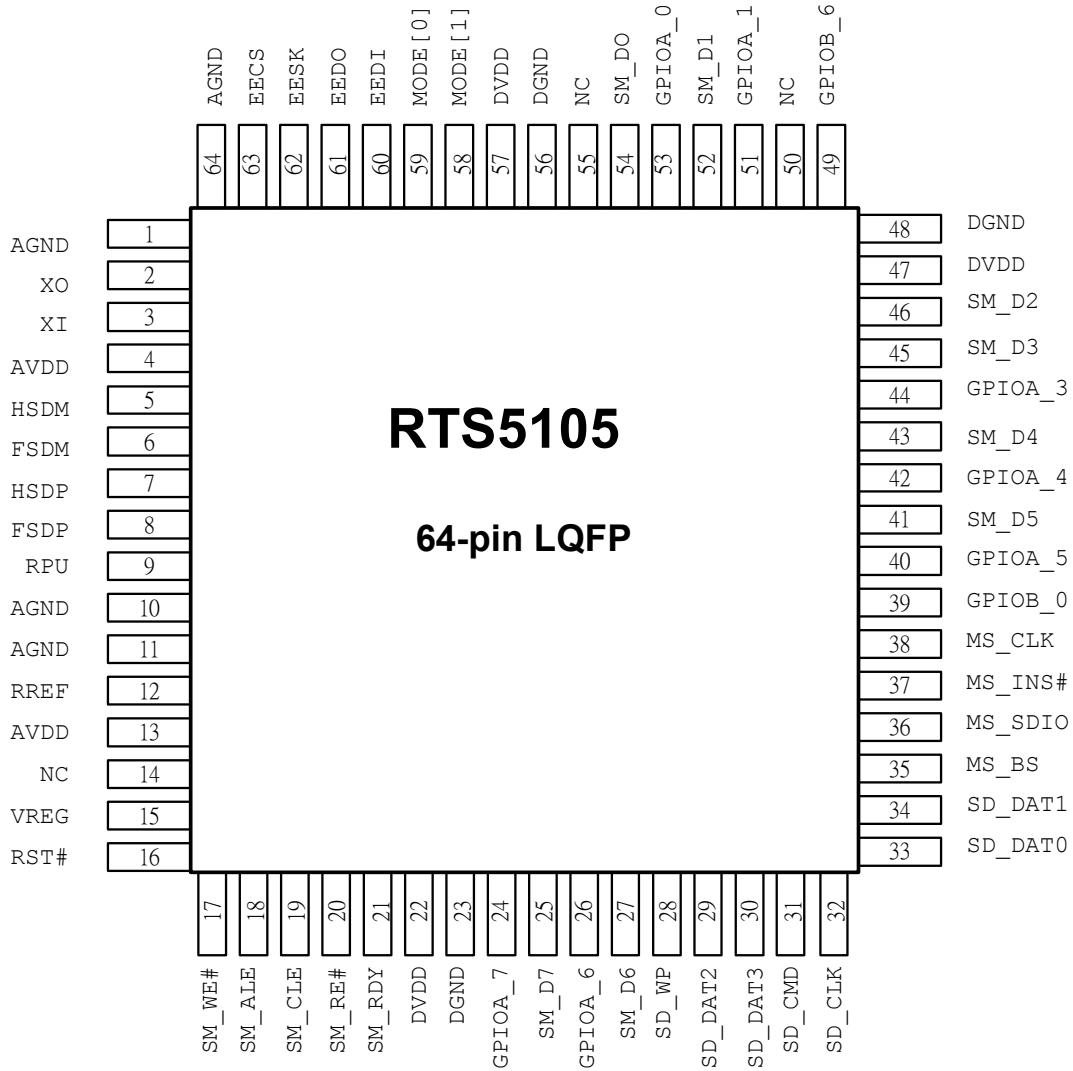

6. Electrical Characteristics

6.1 Absolute Maximum Ratings

Parameter	Rating
Supply Voltage	-0.5V to +4.5V electrical characteristics
Operating Temperature	0°C to +70°
Storage Temperature	-65°C to +150°C
Latchup Current	400 mA
Electrostatic Discharge	5.5K V
Total Power Dissipation	264 mW

6.2 DC Characteristics

Symbol	Description	Conditions	Min.	Typ.	Max.	Unit
V _{DD}	Supply Voltage		3.0	3.3	3.6	V
V _{IH}	Input Voltage High		2		3.6	V
V _{IL}	Input Voltage Low		-0.5		0.8	V
V _{OH}	Output Voltage High		2.4			V
V _{OL}	Output Voltage Low				0.4	V
C _{in}	Input Pin Capacitance				10	pF
I _{DD}	Supply Current	8051 is running @24MHz		80	90	mA
I _{SUS}	Suspend Current	D+ 1.5KΩ resistor is included		350	400	uA

7. Package Dimensions

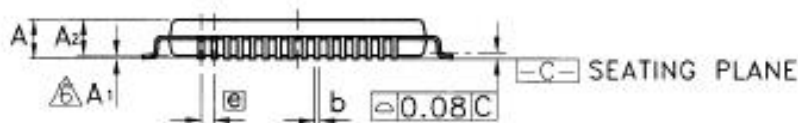
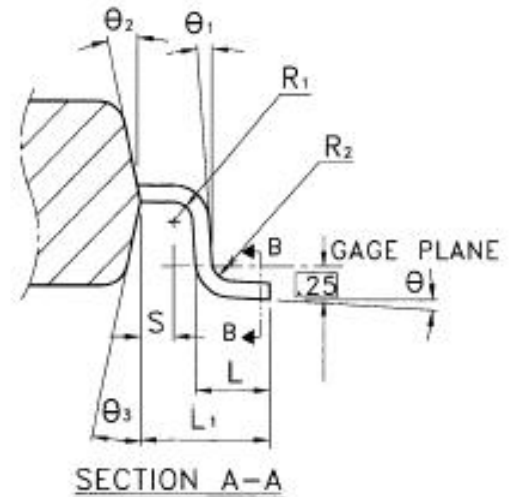
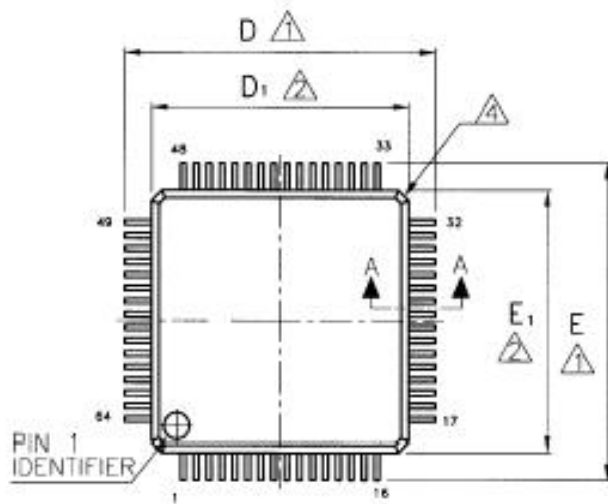

NOTE :

- △ TO BE DETERMINED AT SEATING PLANE $\square\square\square$.
- △ DIMENSIONS D_1 AND E_1 DO NOT INCLUDE MOLD PROTRUSION. D_1 AND E_1 ARE MAXIMUM PLASTIC BODY SIZE DIMENSIONS INCLUDING MOLD MISMATCH.
- △ DIMENSION b DOES NOT INCLUDE DAMBAR PROTRUSION. DAMBAR CAN NOT BE LOCATED ON THE LOWER RADIUS OF THE FOOT.
- △ EXACT SHAPE OF EACH CORNER IS OPTIONAL.
- △ THESE DIMENSIONS APPLY TO THE FLAT SECTION OF THE LEAD BETWEEN 0.10 mm AND 0.25 mm FROM THE LEAD TIP.
- △ A_1 IS DEFINED AS THE DISTANCE FROM THE SEATING PLANE TO THE LOWEST POINT OF THE PACKAGE BODY.
- 7. CONTROLLING DIMENSION : MILLIMETER.
- 8. REFERENCE DOCUMENT : JEDEC MS-026 , BCD.

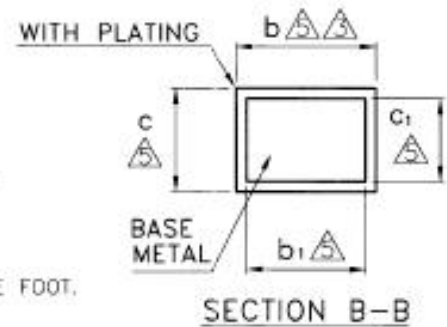

Symbol	Dimension in mm			Dimension in inch		
	Min	Nom	Max	Min	Nom	Max
A	—	—	1.60	—	—	0.063
A ₁	0.05	—	0.15	0.002	—	0.006
A ₂	1.35	1.40	1.45	0.053	0.055	0.057
b	0.17	0.22	0.27	0.007	0.009	0.011
b ₁	0.17	0.20	0.23	0.007	0.008	0.009
c	0.09	—	0.20	0.004	—	0.008
c ₁	0.09	—	0.16	0.004	—	0.006
D	12.00 BSC			0.472 BSC		
D ₁	10.00 BSC			0.394 BSC		
E	12.00 BSC			0.472 BSC		
E ₁	10.00 BSC			0.394 BSC		
e	0.50 BSC			0.020 BSC		
L	0.45	0.60	0.75	0.018	0.024	0.030
L ₁	1.00 REF			0.039 REF		
R ₁	0.08	—	—	0.003	—	—
R ₂	0.08	—	0.20	0.003	—	0.008
S	0.20	—	—	0.008	—	—
θ	0°	3.5°	7°	0°	3.5°	7°
θ ₁	0°	—	—	0°	—	—
θ ₂	12°TYP			12°TYP		
θ ₃	12°TYP			12°TYP		

Realtek Semiconductor Corp.
Headquarters

1F, No. 2, Industry East Road IX, Science-based
Industrial Park, Hsinchu, 300, Taiwan, R.O.C.

Tel: 886-3-5780211 Fax: 886-3-5776047

www.realtek.com.tw